



Energy-efficient  
refurbishment of  
existing housing



energy saving trust™

# Contents

1	Introduction	3
2	Best practice summary	6
3	Energy Saving Trust technical recommendations – Insulation standards	9
4	Energy Saving Trust technical recommendations – Ventilation	19
5	Energy Saving Trust technical recommendations – Airtightness	21
6	Energy Saving Trust technical recommendations – Space heating and hot water	23
7	Energy Saving Trust technical recommendations – Lights and appliances	27
8	Renewable and low-carbon technologies	30
9	Embodied energy	32
10	Energy Saving Trust best practice guidance	33
11	Further information	34
12	Publications	36

Cover image Nelson refurbishment scheme courtesy of Pendle Borough Council.

# 1 Introduction

Every building should be designed and constructed in a way that conserves energy, and reduces carbon dioxide (CO<sub>2</sub>) emissions.

The advice contained within this guide provides examples and specifications for the following scenarios:

- Full refurbishment.
- Works on individual elements.

Home conversions and the issues surrounding the improvement of historic buildings are not explicitly covered within this guide. For assistance on these situations please see the Further information section at the back of this guide.

The following sections cover works to existing housing and what standards need to be achieved.

## 1.1 Minimum standards

Anyone carrying out building work on an item of a property controlled by building regulations is required by law to assess its performance with regards to the conservation of fuel and power.

This involves ascertaining if the controlled item, for example an external wall, meets the requirements of building regulations, and then when required, carrying out energy efficiency improvements (such as the addition of insulation) where this is technically, functionally and economically feasible.

The minimum standards set by building regulations varies across the UK. The following guidance should be consulted to determine the different technical performance requirements, definitions and procedures:

- Communities and Local Government offers a series of 'approved documents' containing guidance on compliance in England and Wales. Part L deals specifically with the conservation of fuel and power.
- The Scottish Building Standards Agency provides guidance on complying in Scotland through a new system of 'technical handbooks' – Section 6 deals with energy use.
- In Northern Ireland, The Building Regulations Unit of the Department of Finance and Personnel provides guidance via a series of 'Technical Booklets' – Technical Booklet F deals with energy use.

These building regulations place minimum standards, i.e. they control elements, fixtures and fittings which are being worked on, added or replaced. Table 1.1 provides guidance upon what is controlled when working on existing housing.

You are advised to check with the area building control team whether or not your proposal requires approval under the regulations.

Please note that complying with the building regulations is a separate matter from obtaining planning permission for work to be undertaken.

**Table 1.1** What items are controlled?

When working on, adding or replacing any of the following items you must check building regulation requirements, and should also consider specifying to Energy Saving Trust best practice standards.

Controlled item	Minimum legislative requirements?	Opportunity to specify Energy Saving Trust best practice?
Home conversions (e.g. garage and loft conversions).	Yes	Yes
Home extensions.	Yes	Yes
Building fabric (e.g. walls, roofs and floors).	Yes	Yes
Replacement openings (windows, doors or rooflights).	Yes	Yes
Heating systems and their control and distribution systems.	Yes	Yes
Other building services (e.g. lighting)	Varies across the UK	Yes

Items not controlled by building regulations include items such as landscaping. Emergency repairs, for example a leaking hot water cylinder, may also be undertaken without delay.

## 1.2 Energy Saving Trust's best practice standards

Home energy use is responsible for over a quarter of UK CO<sub>2</sub> emissions which contribute to climate change. To help mitigate the effects of climate change, the Energy Saving Trust has a range of technical solutions to help UK housing professionals build to higher levels of energy efficiency.

This guide outlines the Energy Saving Trust's best standards for refurbishment. Implementing these recommendations will result in refurbished housing being more energy efficient – reducing CO<sub>2</sub> emissions and saving energy, money and the environment.

Energy efficiency has a vital role in reducing fuel consumption and making warmth affordable. Houses undergoing major refurbishment now are unlikely to be refurbished again before 2050. Current refurbishment work has a major part to play in meeting the UK's long term emissions reduction targets.

Going beyond the minimum standards of building regulations, and adopting the Energy Saving Trust's best practice standards wherever this is technically, functionally and economically feasible can result in dramatically improved levels of energy efficiency being achieved. Opportunities for specifying best practice are provided in Table 1.1.

This guide does not focus on the financial benefits of different measures. However information on savings is contained within the Energy Saving Trust guide 'Domestic energy efficiency primer' (CE101/GPG171), see Further information for more guidance.

## 1.3 Demolition or refurbishment?

Britain has the oldest housing stock in the developed world with 8.5 million properties over 60 years old and whilst there is much talk about the house of the future, at current demolition rates, the average house will have to last for 1000 years before it is replaced. It is vital therefore that we make improving the environmental performance of our old housing stock a priority.

One of the problems that local authorities, regional development agencies and private developers face when choosing whether to refurbish or rebuild, is that the issues they need to consider are broad ranging and complex. Restoring or demolishing the UK's considerable housing stock poses decision-makers with a range of technical, economic, environmental and social issues to grapple with.

One of the tools which can be used to answer these questions is EcoHomes XB. Developed in collaboration with the Housing Corporation, it assists landlords such as housing associations and local authorities in planning and measuring the benefit of improvement works to their housing stock and aiding overall environmental performance.

Where the refurbishment of existing housing is infeasible, the Energy Saving Trust's specification should be adopted as a minimum for any potential new-builds. This holistic approach achieves a 25 per cent reduction in CO<sub>2</sub> emissions using established, cost-effective products and practices. For assistance on achieving the Energy Saving Trust specifications please see the Further information section at the back of this guide.

### 1.3.1 Specifications and tenders

The cost of energy efficient construction can be kept to a minimum by:

- Ensuring that an integrated package of energy efficiency measures is specified.
- Including required energy efficiency measures in the 'standard' tender specification rather than having them priced as extras.
- Assessing the costs and benefits of each energy-saving feature prior to tendering by carrying out energy rating assessments.

## Case study: Nelson, Lancashire



**Before refurbishment**



**Refurbishment nearing completion**

Initially it looked as though 160 of the Victorian mill workers' houses in the Whitefield area of Lancashire would be demolished. However, after a great deal of wrangling, the majority of these have now been salvaged and turned into sustainable homes.

A big issue at Nelson was the potential cost of bringing the former mill workers homes up to modern standards. However, despite many negative issues such as an oversupply of terraced houses which was depressing prices, a backlog of investment in housing and a declining town centre, there was an important positive indicator – the residents of the houses really wanted to continue living in their homes.

The decision to demolish them was challenged, and several key issues were highlighted to tackle not only the potential retention of 160 homes but also – and more critically in terms of sustainability – the long-term viability of the whole area.

The way these issues were tackled resulted in a scheme which is popular, sustainable and economically viable. With the houses now being sold viably on the open market.

### 1.3.2 The SAP home energy rating

The Standard Assessment Procedure (SAP), an energy rating for housing, is based on BREDEM and takes into account space heating, water heating and lighting. It is expressed on a scale of 1 (very inefficient) to 100 (zero energy cost).

SAP is the underpinning assessment methodology behind Energy Performance Certificates.

Although SAP does not provide actual fuel use estimates, it does allow comparison of a dwellings running costs and CO<sub>2</sub> emissions for various energy efficiency measures and packages.

#### **Need assistance?**

Explore a whole range of energy saving measures and receive technical advice by phoning the Energy Saving Trust on 0845 120 77 99, or visit us online at [www.energysavingtrust.org.uk/housing](http://www.energysavingtrust.org.uk/housing)

## 2 Best practice summary

For whole house refurbishment or the replacement of individual components. Where refurbishment has been identified as an appropriate solution the Energy Saving Trust recommendations can be adopted. These measures improve the energy efficiency and reduce the CO<sub>2</sub> emissions of housing.

In housing refurbishment, it is impossible to prescribe a single package of measures applicable to all existing dwellings. However, a range of suitable, cost-effective options are detailed in Table 2.1 [below]. The specification adopted will depend, to a large degree, on the proposed improvements and the form of construction.

**Table 2.1** Recommended improvements

- 1 Walls
- 2 Roofs
- 3 Floors
- 4 Windows
- 5 Doors
- 6 Space heating and hot water
- 7 Airtightness
- 8 Ventilation
- 9 Lights and appliances
- 10 Renewable and low-carbon technologies

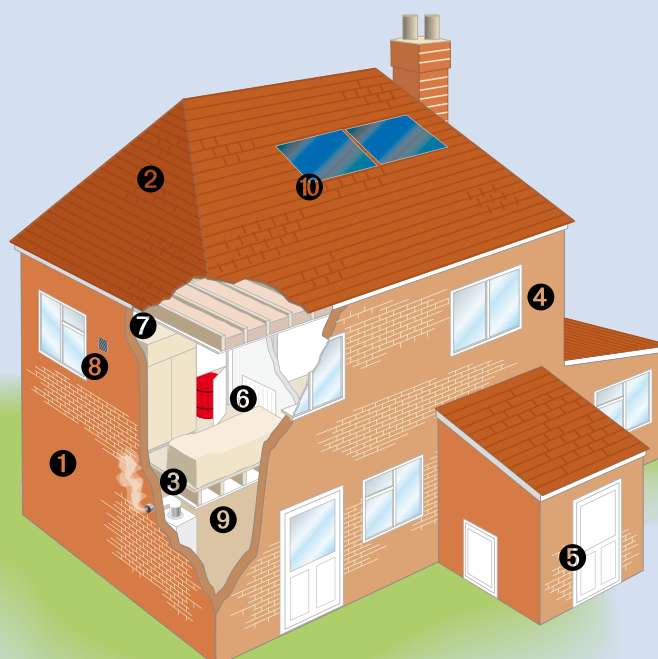

Area	Improvement	See page
1 Walls	Where possible, walls should be insulated to achieve a maximum U-value of 0.30W/m <sup>2</sup> K	11
2 Roofs	For best practice, aim for a U-value of 0.16W/m <sup>2</sup> K when installing insulation between the joists or rafters. Flat roofs should be insulated to achieve a U-value of 0.25W/m <sup>2</sup> K or better.	16
3 Floors	Exposed floors should be insulated to achieve a maximum U-value of 0.20-0.25W/m <sup>2</sup> K (depending upon floor geometry).	–
4 Windows	Replacement windows should have a BFRC rating in band C or above. Any retained windows should be draught-stripped.	18
5 Doors	Replacement doors should have a maximum U-value of 1.0W/m <sup>2</sup> K if solid, or 1.5W/m <sup>2</sup> K if half-glazed. All existing doors should be draught-stripped.	18
6 Space heating and hot water	Domestic wet central heating systems and hot water should be installed to meet 'Central Heating System Specifications (CHeSS) – Year 2005' standard HR6 or HC6. Where electricity is the only option, the recommendations contained within 'Domestic heating by electricity' (CE185/GPG345) should be followed.	23
7 Airtightness	Air leakage paths can be identified using a pressure test and removed by undertaking remedial sealing. The best practice recommendation is to aim for an air permeability of 5m <sup>3</sup> /(h.m <sup>2</sup> ) at 50Pa.	21
8 Ventilation	A purpose-provided ventilation system should be installed.	19
9 Lights and appliances	When re-wiring dedicated lamp fittings should be installed which accept only low-energy bulbs. Ideally greater than 75 per cent of all fixed luminaries should be dedicated low energy fittings. Low energy appliances should be specified which carry the Energy Saving Recommended certification mark.	27
10 Renewable and low-carbon technologies	After all basic energy efficiency improvements have been undertaken the specification of renewable technologies, such as solar hot water heating or photovoltaics, is encouraged where appropriate to further reduce environmental impact.	30

For an interactive guide please visit [www.energysavingtrust.org.uk/housing](http://www.energysavingtrust.org.uk/housing). Energy efficiency improvements can also be combined with virtually all repairs – they need not wait for a full

refurbishment of the building. It is always cheaper to combine them, rather than install them separately. Some of these opportunities are shown in Table 2.2.

**Table 2.2** Opportunities to include energy efficiency in repair and improvement work

Improvement	Opportunity															
	Internal wall insulation	High performance doors and windows	Cavity wall insulation	External wall insulation	Ventilation	Draught-stripping	Insulate loft	Insulate water pipes	Ventilate loft space	Insulate floors	Add porch	Low-energy lighting	Insulate hot water cylinder	Improve controls	A-rated boiler	Sustainable energy sources
Refitting kitchens and bathrooms	✓	✓			✓	✓		✓				✓	✓	✓	✓	
Repointing of walls			✓													
Repairing walls or render – upgrading external appearance		✓		✓												
Replastering	✓															
Replacing wall ties			✓													
Rewiring	✓				✓			✓		✓		✓				
Replacing windows and doors		✓			✓	✓										
Repairing cladding				✓												
Re-roofing / roof repairs							✓	✓	✓							✓
Repairing ground floors						✓		✓		✓						
Repairing heating and plumbing								✓		✓		✓	✓	✓	✓	✓
Increasing security		✓				✓						✓				

## 2.1 Consulting residents

Occupants should be involved in the decisions that affect their homes. This can be done in a number of ways:

- Meetings and discussions with residents' groups.
- Surveys and questionnaires.
- Home visits.
- A general consultation policy (particularly if there are no allocated or existing occupants).

Caretakers and estate management staff should also be involved in the decision-making process.

To help occupants feel involved, landlords and private developers should:

- Discuss proposals with them at an early stage and be open about the issues.
- Provide all available information to allow occupants to make an informed choice.
- Listen to occupants' views and act on them if possible.
- Allow enough time for consultation.

## 2.2 Benefits to the landlord

It is more cost-effective to incorporate energy efficiency measures into planned improvement or repair work than to react on an ad hoc basis to individual problems.

The insulation packages recommended in this document will reduce or eliminate condensation and mould growth, often a significant source of both ad hoc repair work and overall maintenance costs.

## Energy advice

The following suggestions may be helpful in creating an energy advice programme enabling occupants to make effective use of their heating and ventilation systems.

- Following refurbishment, give occupants a specially-written leaflet on how to run their homes in an energy efficient way.
- Ensure that face-to-face advice is given by a trained representative.
- Offer special training to a resident who can act as a local energy advisor.
- Check the setting on each system and provide energy advice to occupants as part of the 'first year defects' inspection.
- Monitor fuel bills (with residents' agreement) and advise occupants on how to reduce them.
- Give advice on energy efficient lighting including the long-term benefits of investing in the more expensive CFLs.
- Provide a durable information sheet, and fix it in a convenient location where it will be read.

For more information on giving good energy advice see the Energy Advice Handbook referenced within the Further information section at the back of this guide.

Any organisation giving energy efficiency advice (or who contract out this service to a third party) should sign up to the Domestic Energy Efficiency Advice Code of Practice, which is run by the Energy Saving Trust. The Code of Practice has been developed to ensure consumers receive accurate and relevant energy efficiency advice and information.

For further details visit:  
[www.goodenergyadvice.org.uk](http://www.goodenergyadvice.org.uk) or  
call the helpline: 020 7222 0101

### 3 Best practice measures: Insulation standards

This section looks at ways of insulating the most common forms of construction. Best practice for each solution is highlighted.

All exposed (and semi-exposed) elements of the dwelling should be insulated to the best possible standard. This will minimise heat loss in the most cost-effective way and reduce thermal bridges. Wherever possible insulation works should take place ahead of heating upgrades in order to reduce heating demand and improve comfort. For insulation, the minimum thermal resistance (R) required is often specified instead of a U-value. The thermal resistance is calculated by

$$R = L/\lambda$$

where R is the required thermal resistance of the insulation in m<sup>2</sup>K/W, L is the thickness of the material in metres and λ is the thermal conductivity of the insulation in W/mK. To compare two insulants of different thickness and thermal conductivity, the R-value is calculated. The one with the higher value

has the better thermal performance. If the required R-value is known, the necessary thickness of a specific insulation material can be calculated.

#### 3.1 New or replacement elements

When undertaking alterations to a dwelling (e.g. replacement of an external wall) or the addition of an extension, to achieve best practice the specifications adopted should be as those for new dwellings as far as practically possible.

#### Further information

For assistance on achieving the Energy Saving Trust best practice recommendations please see the Further reading section at the back of this guide. For more detailed guidance on insulation please see the following Energy Saving Trust literature:

- Insulation materials chart: thermal properties and environmental ratings (CE71).
- Effective use of insulation in dwellings (CE23).
- Practical refurbishment of solid-walled housing (CE184).

**Table 4** Summary of recommended insulation standards

Existing construction element	Typical U-value W/m <sup>2</sup> .K	Improvement measure	Target U-value W/m <sup>2</sup> .K
Cavity walls	1.5	Fill cavity with insulation. It is highly recommended to consider adding additional external or internal insulation to achieve improved levels of performance.	0.5 to 0.6
Solid walls	2.1	Insulate internally using insulation backed dry-lining, insulation with studwork, or insulate externally using wet render, dry cladding or bespoke systems. Between 80 to 140mm of insulation will be required in all cases to achieve the target U-value (dependant upon insulant conductivity).	0.30
Floor	0.70	Insulate above or below concrete slab, or between joists of timber ground floor with between 100 to 200mm of insulation (depending upon geometry).	0.20 to 0.25
Pitched roof (uninsulated)	1.9	Install 250 to 300mm mineral wool quilt (first layer between joists, second layer across joists).	0.16
		Insulate between rafters with insulation in addition to 40 to 100mm of insulation either above or below the rafters (dependant upon insulant conductivity).	0.20
Flat roof	1.5	Add 100 to 160mm of insulation above structural deck (dependant upon insulant conductivity). If replacing a pitched roof should be considered.	0.25
Glazing	3.1	Replace with high performance windows that incorporate integral draught-stripping.	BFRC rating in band C or better

# Insulation standards

## 3.2 Thermal bridging

Thermal bridging is common in older buildings. Even with a high standard of retrofitted insulation, cold spots can occur on internal walls leading to discomfort and condensation. Particular care should be taken where:

- Internal insulation is used.
- The concrete frame, floor slabs or edge beams are exposed.

The details shown in Figures 3.1 to 3.4 represent practical ways in which thermal bridging can be reduced, best practice is to eliminate the bridge completely. However in some situations this is not feasible, in which case the minimum recommendations are shown.

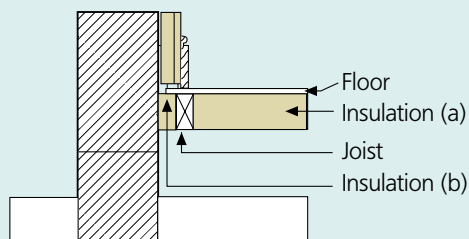

### Best practice

- Specify floor insulation as well as dry-lining to minimise thermal bridging (a).
- AND
- Insulate between the last joist and the wall (b).

Note: Internal insulation should include vapour check on the warm side of the insulation.

Figure 3.1 Timber ground floor junction

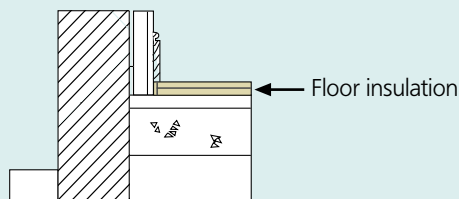

### Best practice

- Butt the floor insulation up against the dry-lining to avoid thermal bridging.

Note: This detail may be impractical if height adjustments to doors and staircases cannot be made.

Figure 3.2 Concrete ground floor junction

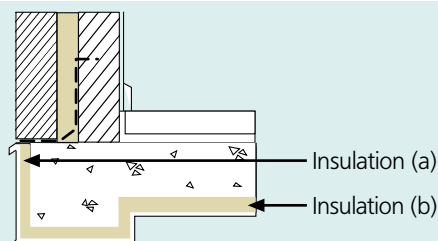

### Minimum recommendations

- Insulate edge of ring beam (a).
- Insulate underside of exposed concrete (b).

Figure 3.3 Exposed concrete floor (e.g. above driveway or garage)

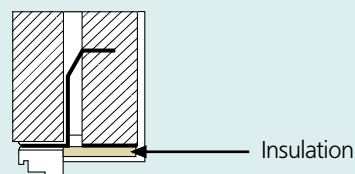

### Minimum recommendations

- Add insulation to soffit and reveals.

Figure 3.4 Steel lintel junction

# Insulation standards

## 3.3 Cavity walls

Unfilled cavity walls can be filled at any time, with heat loss through the walls being reduced by up to 60 per cent. The typical installed cost of cavity wall insulation is around £500, with payback usually occurring in around two years.

### 3.3.1 Description

Installing cavity wall insulation is a specialist job and must be carried out by a suitably qualified contractor: See the Energy Saving Trust publications listed in the Further information section.

A CIGA (Cavity Insulation Guarantee Agency) guarantee should also be provided (excludes non-traditional structures).

### 3.3.2 Suitability of cavity walls

Most masonry cavity walls can be filled with insulation, especially those beneath 12 metres in height built after 1930. In fact, there are systems available for buildings up to 25 metres in height and a few even taller buildings have been successfully cavity-filled, following special assessment.

Almost all of the systems on the market are approved for use in all parts of the UK. However, this assumes that the outer leaf is constructed in accordance with the requirements for local exposure conditions – so that water penetration of the outer leaf is minimal.

The exception is urea formaldehyde foam, which is subject to restrictions in parts of the country and some forms of construction. BS 5617 and BS 5618 provide further information (please see the publications section at the back of this guide).

Where cavity walls are not suitable for cavity insulation they can be treated as solid walls.

### Standard for cavity walls

Best practice for cavity walls is to have them filled with insulation. If the internal surface is being replaced an insulation backed plasterboard should be considered to further improve the thermal performance. It is considered best practice to insulate cavity walls when undertaking any of the following activities:

- Re-plastering or dry-lining of internal surfaces.
- Re-pointing.
- Rendering externally.
- When undertaking a home conversion or adding a conservatory.
- Replacing the heating system (as insulation may allow a smaller, and potentially cheaper system to be specified).

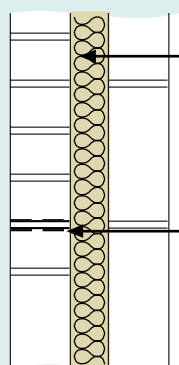

- Air bricks and balanced flues should be sleeved.
- Polystyrene should not be used if there are any unprotected PVC cables in the cavity, or if there are PVC cavity trays or damp proof courses (dpcs).
- Air ventilators crossing the cavity should be sleeved (or sealed if obsolete).

Figure 3.5 Insulation injected into cavity

### Further Information

For more detailed guidance on cavity wall insulation please see 'Cavity wall insulation in existing dwellings: a guide for specifiers and advisors' (CE252)

## 3.4 Solid walls

Solid walls can be insulated internally or externally. A conventional 220mm solid brick wall with internal plaster will have a U-value of 2.1W/m<sup>2</sup>K. Insulating a solid wall to best practice will save around £300 a year on heating costs.

### Standard for solid walls

Applying an insulation with an R-value of 2.9m<sup>2</sup>K/W will improve the wall's U-value to 0.30W/m<sup>2</sup>K. This will require between 80 to 140mm of insulation (dependant upon the insulants conductivity).

# Insulation standards

## 3.5 Internal wall insulation

It is most cost effective to include internal wall insulation in a full refurbishment or modernisation scheme. It is a false economy to install new plumbing, wiring and a central heating system without insulating the dwelling at the same time.

The main types of internal insulation system are:

- Directly applied insulation.
- Internal insulation with studwork.

In both approaches, the number of penetrations through the insulation layer should be kept to a minimum to reduce air leakage.

Figure 3.7 shows a combined layer of a rigid insulation board and insulation-backed plasterboard to achieve a very high level of thermal performance around a window bay.

## 3.5.1 Suitability of internal insulation

- Cheaper than external insulation.
- External wall appearance is maintained.
- Internal wall surface warms up more quickly.
- Easier to install and maintain than external cladding.
- Can leave thermal bridges.
- Fixing of heavy items can be difficult.
- Reduced room size can be critical in small dwellings.
- Skirting boards, cornices, door frames and electrical fittings need repositioning.
- Can be disruptive to occupants.

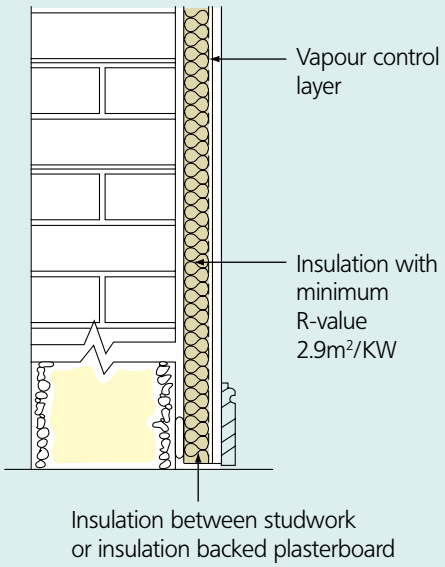

The diagram shows a vertical cross-section of a wall. On the left, there is a window frame with multiple panes. To the right of the window, there is a wall assembly. From left to right, the layers are: a thin vapour control layer, a thick layer of insulation with a minimum R-value of 2.9m²/KW, and a layer of insulation-backed plasterboard. Below the window, there is a label 'Insulation between studwork or insulation backed plasterboard'. To the right of the diagram, there is a list of bullet points.

- Assess the condensation risk in accordance with BS 5250 (2002).
- Apply a rough skim of mortar down to skirting level, and up to ceiling level on any perimeter walls and seal around any penetrations through the wall to reduce air leakage.
- Install mechanical fixings in accordance with the manufacturer's recommendations.
- Insulation should be returned into the reveals and soffits of window and door openings.
- PVC-sheathed electrical cables should not come into contact with polystyrene insulation as this can degrade the integrity of the cable insulation.
- Return the insulated dry-lining a short distance along separating walls, floors and ceilings to avoid condensation at the thermal bridge.

Figure 3.6 Internal wall insulation



Figure 3.7 Insulation around window bay

### Further Information

For more detailed guidance on internal wall insulation please see 'Practical refurbishment of solid-walled houses' (CE184).

# Insulation standards

## 3.6 External wall insulation

External insulation is generally the more expensive way to insulate. However for constructions that require periodic re-rendering such as no-fines concrete, or where extensive remedial action is needed (to combat rain penetration, for example), then the extra cost of additional insulation is relatively low.

The design and installation of external wall insulation systems is a specialist job. Use an insulation system with current approvals certificates for all components.

The main types of external insulation system are:

- Wet render systems.
- Dry cladding systems.

As insulation and fixing components are common to most wet render systems, performance generally depends on the thickness of insulation and quality of the render.

Dry cladding is particularly suitable where fixings can only be used on particular areas of the building. In addition, these systems permit access for periodic checks or maintenance work, as is often required with high-rise buildings. Dry cladding is rarely used on low-rise dwellings as the cost is prohibitive.

### 3.6.1 Suitability of external wall insulation

- Can be applied while occupants remain in residence.
- Thermal bridging is avoided, except in the case of projections such as balconies.
- Can change external appearance dramatically.
- Can be used to revitalise and modernise a property and so extend its life.
- Can be cost effective where the external walls require remediation.
- May be vulnerable to impact damage.
- Vulnerable areas need protection.
- Rainwater goods and sills usually require work.

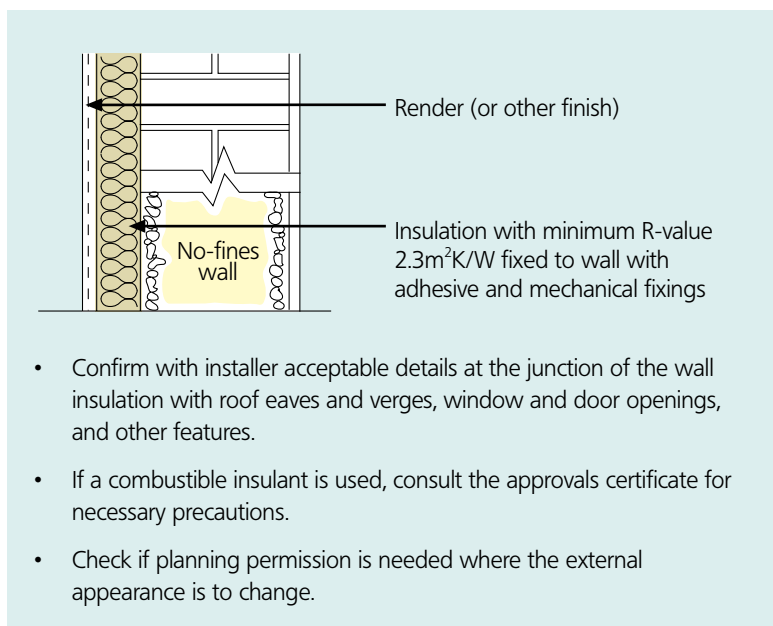

Figure 3.8 External insulation

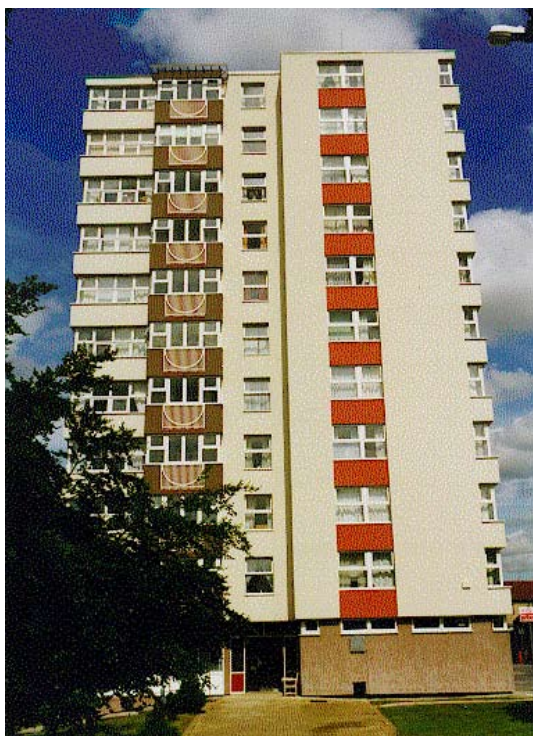

Figure 3.9 Example of a refurbished high-rise building – Moorfield, by Bristol City Council

### Further Information

For more detailed guidance on internal wall insulation please see “External insulation systems for walls of dwellings’ (CE118/GPG293).

# Insulation standards

## 3.7 Floors

Heat loss through exposed floors depends on: the size and shape; the type of floor; and the conductivity of the ground below it. Heat loss is greatest around the edges of the floor, so shape is important. Losses would differ between, say, a mid-terrace and an end-terrace dwelling. Specifying a common U-value for both would result in different insulation thicknesses and finished floor levels. This is not practical. It is easier to specify an R-value than a U-value.

Heat loss through floors can be reduced by up to 60 per cent by adding insulation, with an annual saving of around £45.

### Standard

**Solid floor:** R-value of  $2.5\text{m}^2\text{K/W}$ .

**Timber suspended floor:** R-value of  $3.75\text{m}^2\text{K/W}$ .

This will generally achieve a U-value between 0.20 to  $0.25\text{W/m}^2\text{K}$

### 3.7.1 Solid concrete floors

Where the floor is being retained the only simple option is to install insulation and a new deck on top. However care needs to be taken, particularly at stairs and door thresholds. A 60mm layer of phenolic, polyisocyanurate or polyurethane foam insulants can achieve best practice.

Where the screed or ground floor slab is being replaced there is an opportunity to incorporate insulation. The finished floor level should coincide with the previous level if possible in order to avoid unequal or excessive step heights at doors or staircases. Insulation can be added above or below the slab.

### 3.7.2 Suitability

**Insulation above the slab** If the insulation is placed above the slab, the room will warm up more quickly when the heating is switched on. The damp proof membrane should be placed above the concrete slab. Moisture-resistant flooring grade chipboard should be used, with room for expansion around the edges.

**Insulation below the slab** This is the preferred option in a warm south-facing room. The concrete slab on top helps absorb heat and limits overheating. An up-stand of insulation (R-value of  $0.75\text{m}^2\text{K/W}$ ) the same height as the slab should be put around the perimeter of the room. Joints between the insulation boards should be taped with water-resistant tape to stop concrete seepage.

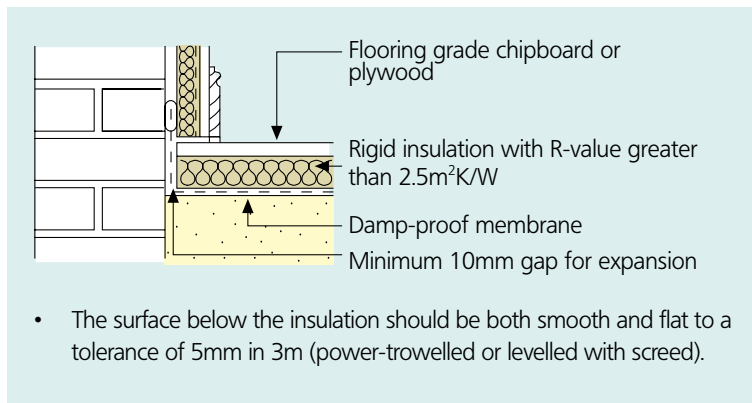

Figure 3.10 Concrete ground-bearing slab with insulation above slab

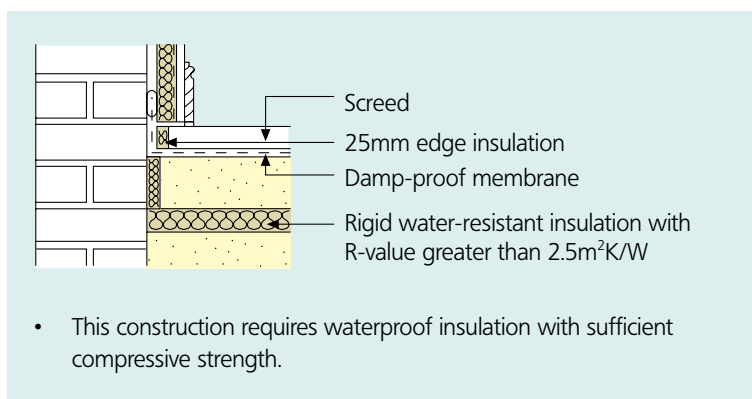

Figure 3.11 Concrete ground-bearing slab with Insulation below slab

# Insulation standards

## 3.7.2 Suspended timber floors

Insulation should fully fill the space between the joists and be the full depth of the joist. If there is a cellar or basement, insulation can easily be installed from below (see Figure 3.12). Building control should be consulted to ensure correct fire performance is achieved. Mineral wool or rigid insulating boards can be used. The insulation should be placed tight up to the underside of the floor but not be over-compressed.

Where there is no access from below, the only practical way to insulate the floor is by taking up the floorboards (see Figure 3.13). Timber suspended floors can suffer with draughts – from between the floorboards, around radiator pipes and under the skirting boards. These need to be sealed. Membranes, expanding foam and mastic all have a role to play here. All timbers should be inspected for damp, rot or infestation prior to the addition of insulation.

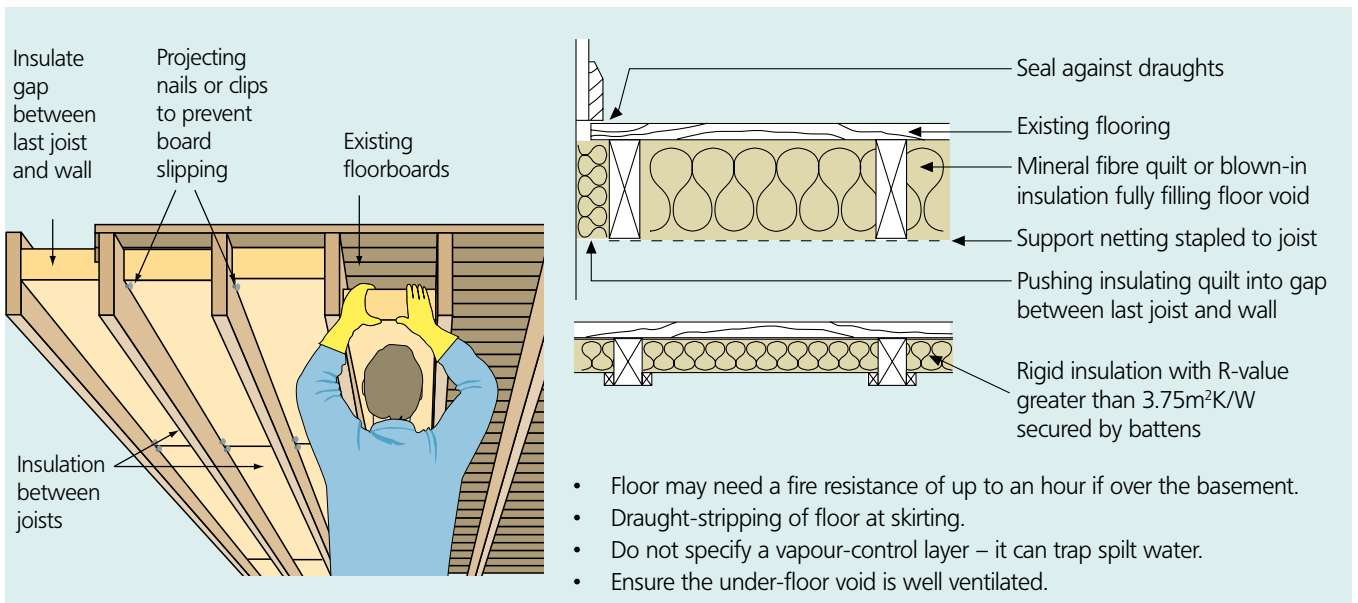

**Figure 3.12** Suspended timber ground floors, access from below

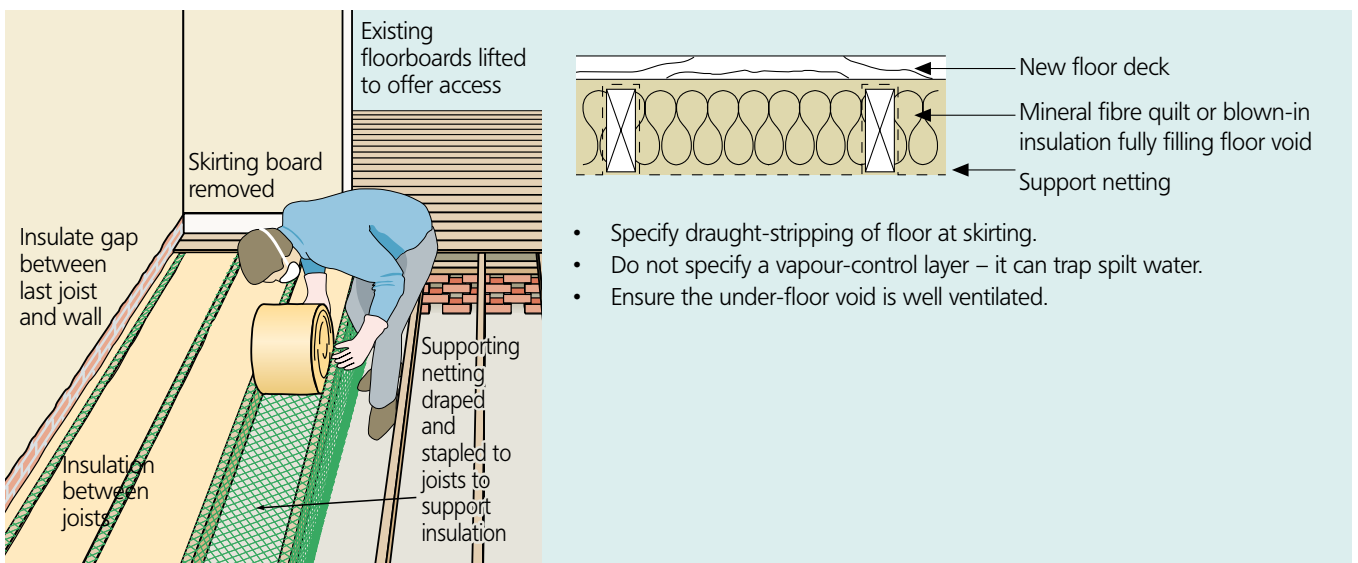

**Figure 3.13** Suspended timber ground floors, access from above

**Further Information** For more detailed guidance on internal wall insulation please see 'Practical refurbishment of solid-walled houses' (CE184)

# Insulation standards

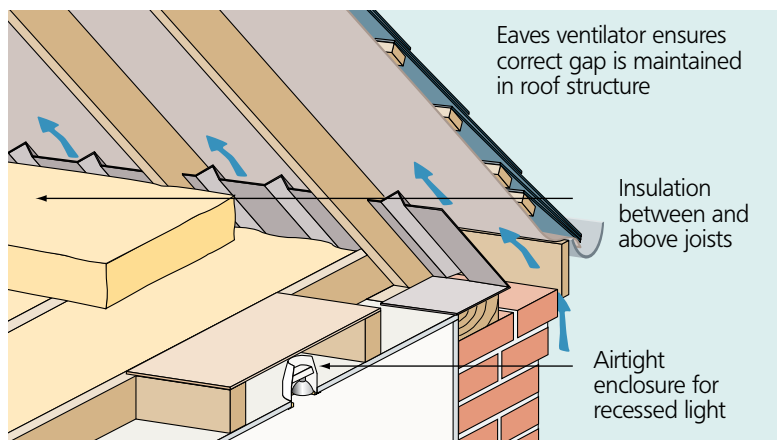

**Figure 3.14** Best practice for roof insulation at ceiling level – between and over joists

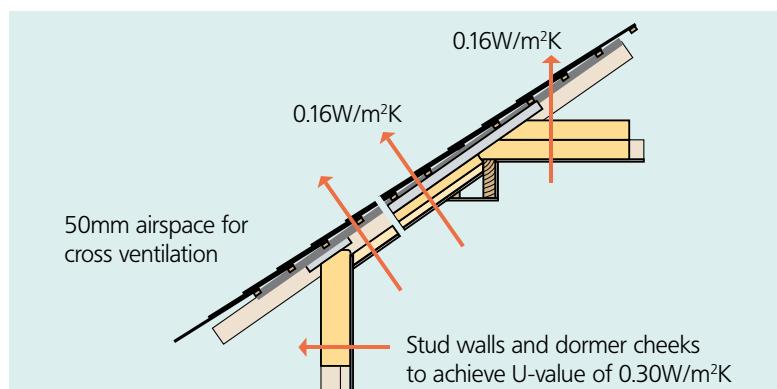

**Figure 3.15** Best practice for roof insulation between and below the rafters

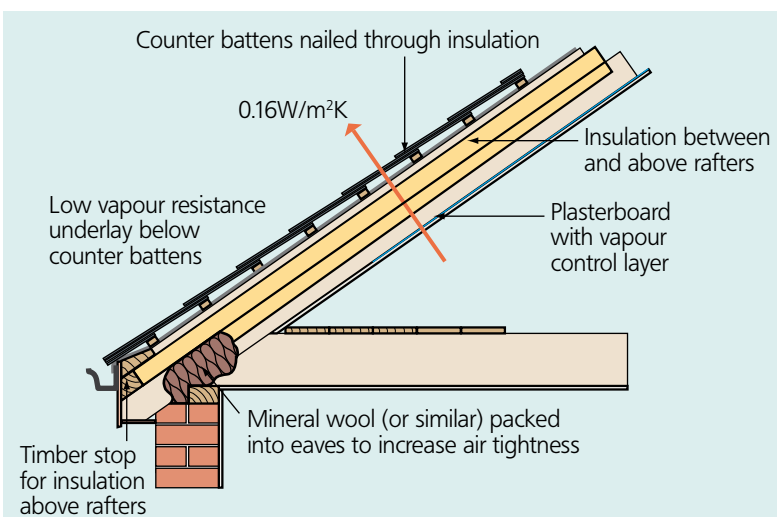

**Figure 3.16** Best practice for roof insulation between and above the rafters

## 3.8 Roofs

Lofts are the easiest to insulate – either insulating between the joists, or at roof level in the rafters. Attic rooms and flat roofs can be insulated, but the work is best done during a conversion or major renovation.

Loft insulation usually costs from around £500 with the payback occurring after two years if the loft was previously uninsulated.

### Standard

For best practice, aim for a U-value of  $0.16\text{W/m}^2\text{K}$  when installing insulation between the joists or rafters (for rooms in the roof any stud walls and dormer cheeks should aim to achieve a U-value of  $0.30\text{W/m}^2\text{K}$  or better).

Sometimes achieving best practice U-values may require large insulation thicknesses (for example over 60mm below rafters). This may reduce internal space and headroom. In these restricted situations, it may be more practical to aim for a U-value of  $0.20\text{W/m}^2\text{K}$ . Flat roofs should be insulated to achieve a U-value of  $0.25\text{W/m}^2\text{K}$  or better.

### 3.8.1 Pitched roofs

Pitched roofs can be insulated at the ceiling level, between the joists, or between the rafters (where there is an existing attic room or a new 'room in the roof'). In all roof constructions, interstitial condensation should be avoided. The location of services and how these run in relation to the roof insulation layer must also be given due consideration.

- Seal any holes around services, especially those from kitchens, bathrooms and airing cupboards.
- Keep electrical cables above the insulation to avoid overheating.
- Avoid placing tanks and pipes in the roof if possible (low mains water pressure may not make this possible).
- Any pipes or tanks located in the roof space must be adequately insulated.

# Insulation standards

## 3.8.2 Flat roofs

The preferred method of insulating a flat roof is to locate the insulation above the roof deck. The insulation can either be placed below the weatherproof membrane in a warm roof deck construction, or above the waterproof membrane in an inverted warm deck. It is most economical to add insulation when replacing the roof covering.

### Warm deck construction

- Insulation boards to be rigid.
- Insulation materials must be compatible with any bonding materials used for the weatherproof membrane.
- Voids in timber roof must not be ventilated to the outside.

### Inverted warm deck construction

- The existing roof structure must be capable of supporting the extra weight, particularly of the ballast layer

#### Further information

For more detailed guidance on roof insulation please see the following Energy Saving Trust literature:

- Practical refurbishment of solid-walled houses (CE184).
- Energy efficient loft conversions (CE120).

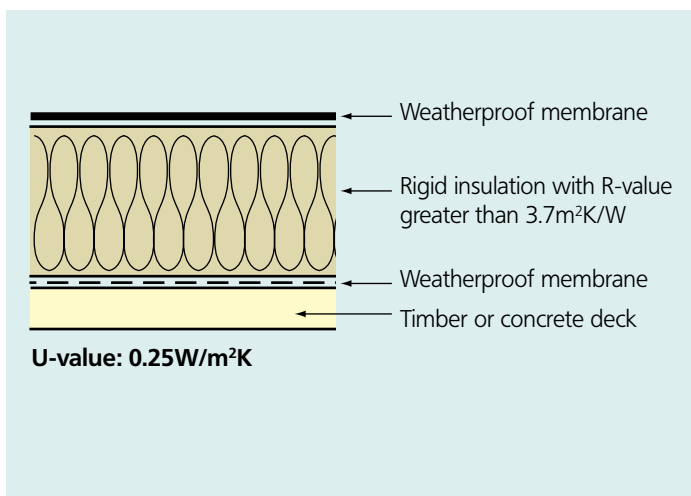

Figure 3.17 Warm deck construction

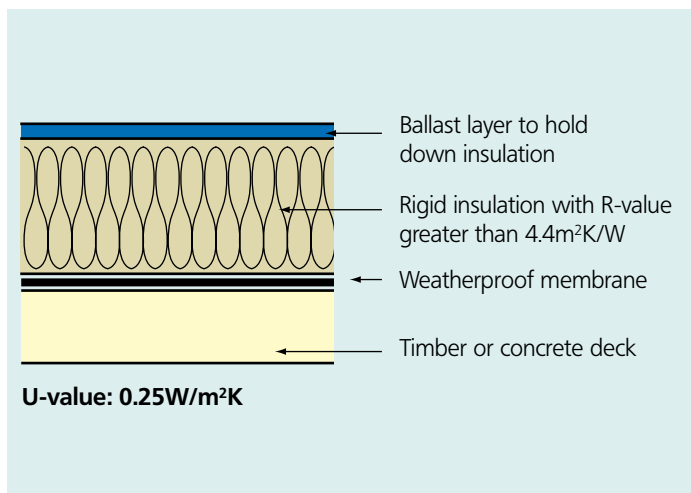

Figure 3.18 Inverted warm deck construction

# Insulation standards

## 3.9 Windows and doors

The replacement of windows and doors can have a significant impact on heat loss from a dwelling. The greatest impact comes through the reduction of infiltration heat losses from minimising draughts.

### Best practice

Windows with a British Fenestration Rating Council (BFRC) Rating in band C or better

**Solid insulated door:** Maximum U-value of 1.0W/m<sup>2</sup>K

**Half-glazed insulated door:** Maximum U-value of 1.5W/m<sup>2</sup>K

Replacement windows should always be fitted by a reputable installer and sealed around the frame (to reduce draughts and air leakage at the wall-to-frame junction). In England and Wales, a FENSA registered installer should be used (please see 'Relevant organisations and websites').

Replacement of windows in historically sensitive buildings should only be undertaken after consultation with the local authority's building conservation officer.

Secondary glazing is a good option where thermal performance needs to be improved and the existing character of the dwelling needs to be maintained.

Draught-stripping of existing badly fitting windows and doors is inexpensive and simple to install. It can greatly improve comfort as well as reducing heat loss.

A window's thermal performance depends on a number of factors including: design, the materials used and the combination of components.

The BFRC has developed a system for comparing the overall energy performance of windows. More information can be found at: [www.bfrc.org](http://www.bfrc.org)

The rating system is based on the total annual energy flow through the window (kWh/m<sup>2</sup>/yr).

The ratings are grouped into bands from A-G. It is anticipated that the BFRC Rating will eventually replace U-values as the main UK method for specifying windows.

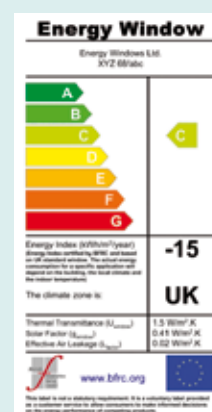

### Further information

For more detailed guidance on windows and doors please see the following Energy Saving Trust literature:

- Windows for new and existing houses (CE66).
- Energy efficient historic homes – case studies (CE138).

**Table 5** Best practice for replacement windows

	Frame type	Glass layers	Glass type	Air gap (mm)	Gas fill	Spacer	BFRC Rating	Band	U-value
Best practice	PVC-U (5 chamber)	3	2 x low iron 1 x hard coat	16 x 2	Argon	Warm edge hybrid	+4	A	1.3
	PVC-U (5 chamber)	2	soft coat	16	Argon	Silicone rubber	-8	B	1.4
	PVC-U (3 chamber)	2	soft coat	16	Argon	Silicone rubber	-13	C	1.5
	Timber	2	soft coat	16	Argon	Corrugated metal strip	-16	C	1.5
	PVC-U (5 chamber)	2	soft coat	16	Argon	Hard polyurethane	-18	C	1.6
	Timber	2	soft coat	16	Air	Silicone rubber	-22	D	1.6
	PVC-U (5 chamber)	2	soft coat	16	Argon	Aluminium	-23	D	1.6
	Aluminium (23mm polyamide breaks)	2	soft coat	16	Argon	Silicone rubber	-26	D	1.8
	Timber	2	hard coat	16	Air	Silicone rubber	-27	D	1.8

## 4 Energy Saving Trust technical recommendations – Ventilation

Purpose-provided ventilation (e.g. ventilators and windows) and extract fans are required to replace stale indoor air with fresh outdoor air.

Adequate ventilation is needed for both the comfort and the safety of occupants, as it removes or dilutes pollutants that accumulate in the dwelling.

Once the dwelling is sufficiently airtight, controlled ventilation can be installed. The main systems are described briefly below.

Relevant national standards and regulations should be followed.

### 4.1 Natural background ventilators

Background ventilators are required in order to provide a minimum supply of fresh air for occupants and to disperse residual water vapour. Background ventilators provide continuous ventilation throughout the dwelling.

These are an essential part of most ventilation strategies as they provide the minimum failsafe background ventilation for all types of systems.

This is not the type of ventilator specified for combustion devices in UK building regulations, which must remain permanently open. The BRE information paper 'Background ventilators for dwellings' (see Further information section) gives full details of each different type.

### 4.2 Passive stack ventilation (PSV)

The layout of existing dwellings usually makes passive stack ventilation difficult to incorporate. However, adequate levels of ventilation can be achieved by this method.

PSV is a system of vertical or near-vertical ducts that run from the kitchen and bathroom to vents on the roof. Moist air is extracted by the stack effect – warm air is less dense and so rises – and by the effect of wind flows over the roof. Extract grilles with humidity control should be specified. Fresh air entering the dwelling should be controlled with trickle vents (preferably also with humidity control).

The most obvious energy saving feature of PSV systems is that they consume no electricity. However, they do exhaust heat energy.

### 4.3 Local extract fans

Extract fans remove stale or polluted air from kitchens and bathrooms, while fresh air is drawn into the building via background ventilators in other rooms. Building regulations in each part of the UK give the required extract rates for fans.

Low power extract fans using DC motors are now readily available, saving up to 80 per cent of the electricity required by conventional units. Ideally, all extract fans should have a humidistat controller to keep the room humidity at an acceptable level, normally below 70 per cent relative humidity.

For effective ventilation, extract fans should be located:

- As high as possible in the room.
- Close to the source of the pollution.
- As far as possible from the source of fresh air.
- In accordance with manufacturers' recommendations.

Passive infra-red (PIR) detectors (built-in or remote) can be used to activate this type of fan. Usage detection controls can turn on extract systems when a specific appliance, for example a shower, is used.

If occupants are made aware of the importance and low running costs of local extract fans, there is less likelihood they will disable them.

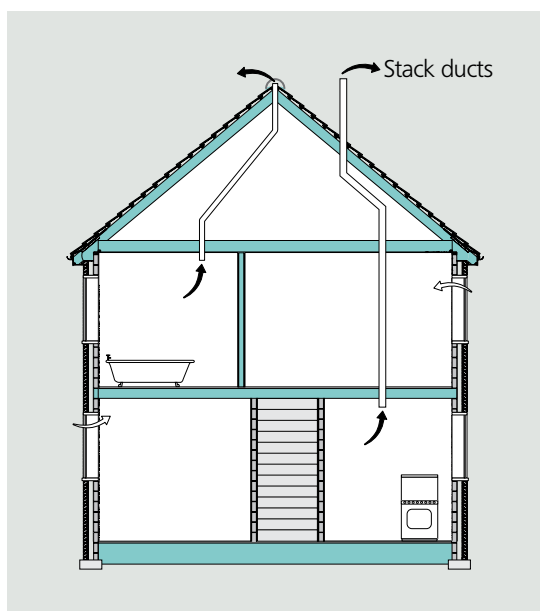

Figure 4.1 Passive stack ventilation

# Ventilation

## 4.3 Single room heat recovery ventilators (SRHRVs)

The single room heat recovery ventilator is a development of the extract fan which incorporates a heat exchanger. It recovers 60 per cent or more of the heat in the outgoing air. This can then be used to preheat incoming air.

The supply and extract fans are often dual speed, providing low-speed continuous 'trickle' intake, and high-speed 'boost' extract. The higher speed setting can be controlled manually, via a humidistat or usage detection control system.

The design considerations regarding location are similar to those for extract fans.

## 4.4 Mechanical extract ventilation (MEV)

An MEV system continually extracts air from 'wet' rooms such as kitchens and bathrooms.

It usually consists of a central ventilation unit positioned in a cupboard or loft space, ducted through the dwelling to extract air from the wet rooms. The supply air needs to be controlled and the inlet vents need to be positioned where they will not cause discomfort. Passive vents may be appropriate.

To qualify as best practice standard, the whole system must have a specific fan power of 0.6W/l/s or less when tested in the appropriate configuration via SAP Appendix Q. Further information on SAP Appendix Q, the test methodologies and test results of eligible systems can be found at [www.sap-appendixq.org.uk](http://www.sap-appendixq.org.uk)

## 4.5 Whole house mechanical ventilation with heat recovery

These systems deliver the required ventilation rate almost independently of weather conditions. However, the energy saving benefits will only be realised in airtight properties. Therefore this type of system should only be used in properties with an airtightness better than  $5\text{m}^3/(\text{h}\cdot\text{m}^2)$  at 50Pa pressure.

The good practice standard is met by following the relevant national standards and regulations. To qualify as best practice standard, the whole system must have:

- A specific fan power of 1W/l/s or less
- A heat recovery efficiency of 85 per cent or higher

Both when tested in the appropriate configuration via SAP Appendix Q. Further information on SAP Appendix Q, the test methodologies and test results of eligible systems can be found at [www.sap-appendixq.org.uk](http://www.sap-appendixq.org.uk)

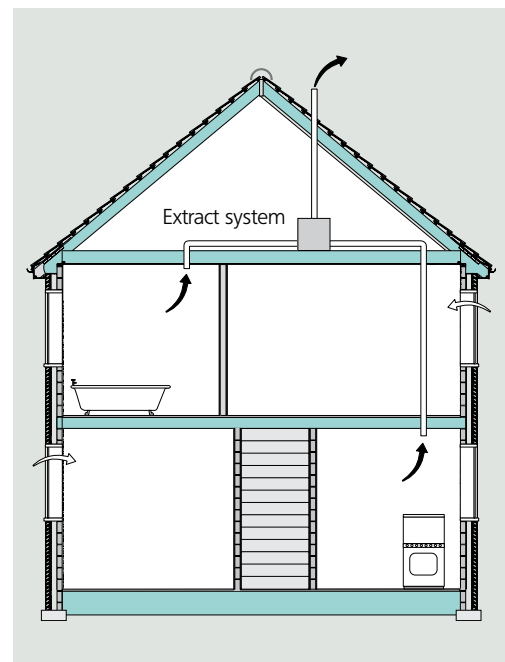

Figure 4.2 Mechanical extract ventilation (MEV)

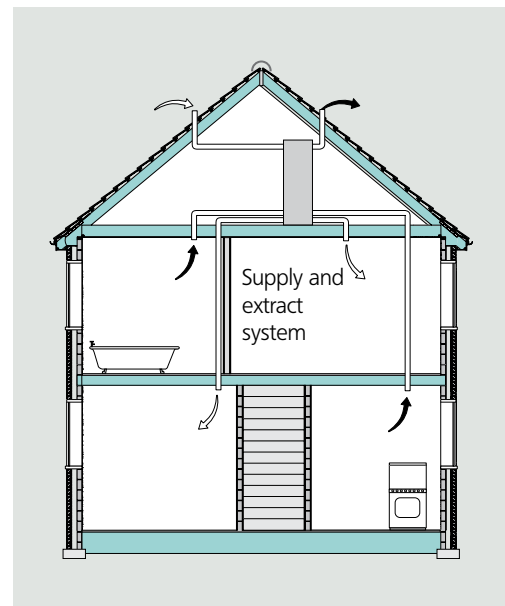

Figure 4.3 Whole house mechanical ventilation with heat recovery

### Further information

For more detailed guidance on ventilation please see the 'Energy efficient ventilation in dwellings' (CE124/GPG268).

## 5 Energy Saving Trust technical recommendations – Airtightness

A ventilation and airtightness strategy should be part of any refurbishment works. The objective is to provide a balance between energy efficiency and indoor air quality.

Air leakage is the infiltration of air via unwanted gaps and cracks in the building envelope.

Too much air leakage leads to heat loss as well as discomfort from cold draughts. The principal air leakage pathways are illustrated in Figure 5.1. As thermal insulation standards improve the proportion of total heat lost via infiltration increases significantly.

As a part of any major refurbishment works air leakage paths should be identified and minimised. A pressure test may be used to identify air leakage pathways suitable for remediation works.

The potential to improve airtightness of a dwelling will depend on the nature of the existing building and the type of works being undertaken. It is therefore difficult to set absolute targets but the best practice recommendation is to aim for an air permeability of  $5\text{m}^3/(\text{h}\cdot\text{m}^2)$  @ 50Pa.

The results of an airtightness test can be used to:

- Assess the airtightness of the dwelling against recognised standards.
- Identify air leakage paths and the rate of air leakage.
- Assess the potential for reducing air leakage in the dwelling.
- Measure improvements achieved by remediation work.

Please note that care must be taken when dealing with historic buildings.

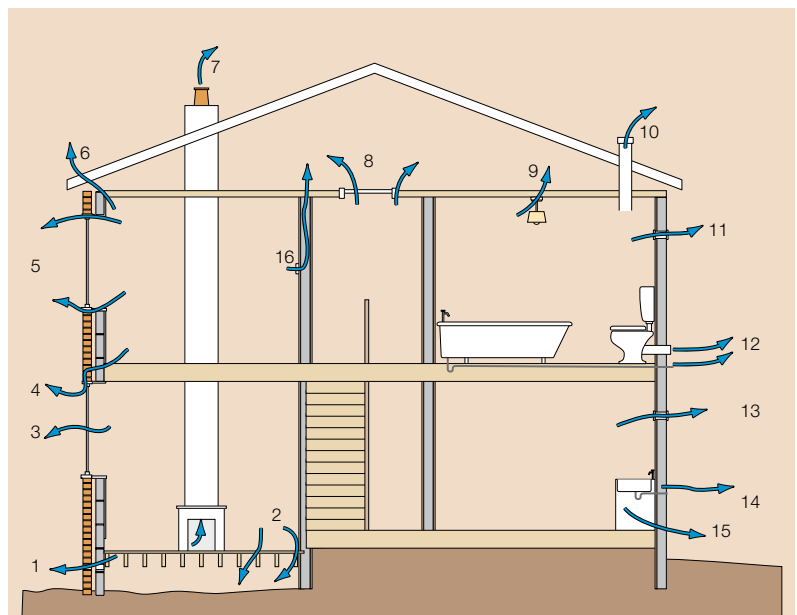

### Most common air leakage paths

- 1 Underfloor ventilator grilles.
- 2 Gaps in and around suspended timber floors.
- 3 Leaky windows or doors.
- 4 Pathways through floor/ceiling voids into cavity walls and then to the outside.
- 5 Gaps around windows.
- 6 Gaps at the ceiling-to-wall joint at the eaves.
- 7 Open chimneys.
- 8 Gaps around loft hatches.
- 9 Service penetrations through ceilings.
- 10 Vents penetrating the ceiling/roof.
- 11 Bathroom wall vent or extract fan.
- 12 Gaps around bathroom waste pipes.
- 13 Kitchen wall vent or extractor fan.
- 14 Gaps around kitchen waste pipes.
- 15 Gaps around floor-to-wall joints (particularly with timber frame).
- 16 Gaps in and around electrical fittings in hollow walls.

**Figure 5.1** The most common air leakage paths.

# Airtightness

## 5.1 Disadvantages of draughty dwellings

### CO<sub>2</sub>

There will be higher emissions.

### Space heating

Excessive heat loss means that a correctly-sized heating system may not be able to satisfy demand.

### Comfort

Draughts and cold spots can cause discomfort. Excessive air leakage may make rooms uncomfortably cold. Draughty dwellings tend to give rise to complaints from occupants.

### Risk of deterioration

Damp air can penetrate the building fabric, degrading the structure and reducing the effectiveness of the insulation. Air leakage paths often produce unsightly dust marks on carpets and wall coverings.

### Further Information

For more detailed guidance on airtightness and ventilation please see the following Energy Saving Trust literature:

- Improving air tightness in dwellings (CE137/GPG224).
- Energy efficient ventilation in dwellings (CE124/GPG268).
- Energy efficient historic homes – case studies (CE138).

**Table 5.1.** How to improve airtightness in existing dwellings

<b>Windows and doors</b>	Seal gaps around windows and doors to prevent air leakage via the reveals and thresholds.
	Apply an external mastic seal to all window and door frames.
	Seal any internal gaps where the wall reveals/window boards abut window units or external doors with a bead of mastic.
	Repair any damage to window frames and ensure the casements, sashes and top-lights close firmly. It may be necessary to replace closing mechanisms.
	Apply draught-stripping to gaps around window casements, sashes and top-lights.
<b>Walls</b>	Air leakage behind dry-lining can be reduced by injecting continuous ribbons of expanding polyurethane foam between the plasterboard sheets and the inner leaf blockwork.
	Make good damage to mortar joints and fill holes in external walls.
<b>Floor</b>	Improve timber floors by laying hardboard sheeting over the top. Do not use plastic sheeting to cover timber floors as this may cause the timber to rot.
	Seal around the edges of the room and make good any gaps around service pipes.
<b>Roof</b>	Ensure the loft hatch fits snugly into its aperture and apply draught-stripping between the hatch and the frame.
<b>Services</b>	Seal gaps around any service pipes and cables passing through external walls, ceilings and ground floors.

## 6 Energy Saving Trust technical recommendations – Space heating and hot water

Space heating provides thermal comfort where and when required. Heat gains from the sun, occupants, the hot water system, cooking and electrical appliances supplement the main heating source.

An energy efficient heating system:

- Is correctly sized to warm up the dwelling from cold within a reasonable time (normally one hour).
- Uses fuel as efficiently as possible.
- Can be accurately controlled.
- Has controls that are easy to use and understand.

An efficient system will have low running costs and can increase the value of a property.

A complete system replacement provides the best opportunity for improving energy efficiency. It also allows a reassessment of fuel choice: this has a great influence on the running costs and on the system's environmental impact. A partial upgrade can give many of the same benefits, particularly when controls and insulation are improved or the boiler replaced.

### 6.1 Fuel choice

The choice of fuel depends on availability and affects running costs and CO<sub>2</sub> emissions as shown in Figure 6.1. Due to the significantly lower carbon emissions natural gas, where available, is the preferred fuel for wet heating systems.

The fuel prices and associated CO<sub>2</sub> emissions used in the comparison are taken from SAP2005. Current prices should be checked when selecting a fuel.

Electric resistance heating should only be used where all insulation measures have been adopted.

### 6.2 Recommended upgrade package

The recommended heating upgrade packages are the best practice specification set out in CHES (see Table 6.1).

Systems need to be correctly sized. A number of factors should be considered, particularly for new systems in homes where the fabric insulation has been upgraded:

- Ventilation heat losses need to be addressed.
- The size of the boiler will be determined by hot water demand as well as space-heating needs.
- The size of the new boiler should take insulation improvements into account.
- The system should be accurately controlled to its design temperatures set out in BS 5449.

It is vital that occupants are consulted and advised on how best to operate their new systems. For more information on energy advice see the Energy Advice Handbook in the Further information section of this guide.

**Space and water heating – running costs and CO<sub>2</sub> emissions**

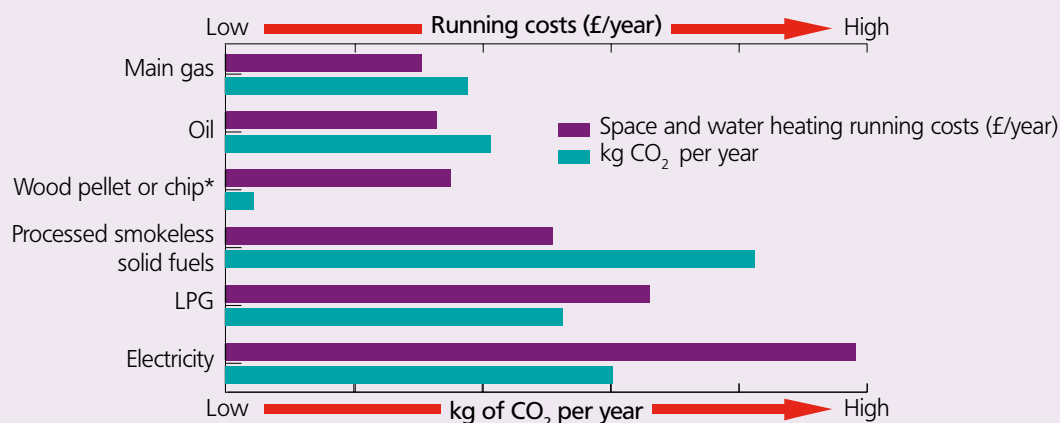

\* Chipped or pelleted fuel is only available in a few areas and the price can vary considerably. At present there is no labelling scheme for wood pellets or chips. This means that without verification of the source, levels of emissions and air pollution cannot be guaranteed.

**Figure 6.1** Space and water heating – running costs and carbon dioxide emissions

### 6.3 Seasonal boiler efficiency

The SEDBUK (Seasonal Efficiency of Domestic Boilers in the UK) rating is a measure of the efficiency of a boiler installed in typical domestic conditions in the UK and is used in the SAP. The efficiency of most boilers can be found on the Governments boiler efficiency database [www.boilers.org.uk](http://www.boilers.org.uk)

#### How the designer can help?

Heating system controls should be simple to understand and easy to adjust:

- Specify a heating timeswitch that is easy to read and set, and has a default program.
- Locate the timeswitch where it is easily visible and accessible.
- Specify room and cylinder thermostats with the 'usual' temperate range clearly marked.
- Heating controls should have a low-temperature limit option which can be simply set should the occupant plan to be away for more than a day.
- Any electric immersion heater fitted to the hot water cylinder as a back-up must have adjustable thermostatic control and a light outside the cupboard indicating when it is in use.

### 6.4 Condensing boilers

The energy performance standard for new and replacement boilers was raised in England and Wales in April 2005, Northern Ireland in November 2006 and Scotland in May 2007. When replacing a boiler, a condensing boiler (with a seasonal efficiency of greater than 86 per cent) must now be installed in the majority of cases.

### 6.5 Combination boilers (combi)

Combi boilers provide space heating and 'instant' mains-pressure hot water. They do not require header or hot water storage tanks. The power of the boiler is normally selected on the basis of the hot water requirement. Choosing between a combi and a regular boiler is discussed in the Energy Saving Trust publications CE29, CE30 and CE47.

Some instantaneous combi boilers have a 'keep hot' facility (sometimes called 'warm-start') which keeps water within the boiler permanently hot to reduce warm-up time at boiler start-up. The keep hot facility must be timed to switch off overnight as its use may increase running costs.

### 6.6 Radiators

Placing insulation with a reflective coating behind radiators on uninsulated external walls will increase their effectiveness. However, improved wall insulation gives greater benefit.

**Table 6.1** CHeSS HR6 and HC6 specifications

	Regular system (CHeSS – HR6)	Combi system (CHeSS HC6)
Description	Domestic wet central heating system with regular boiler and separate hot water store	Domestic wet central heating system with combi or CPSU boiler.
Boiler	SEDBUK Band A rating	SEDBUK Band A rating (A or B for oil)
Hot water store	High-performance hot water cylinder, or high performance thermal storage system	None, unless included within boiler
Controls	Programmable room thermostat with additional timing capacity for hot water	Programmable room thermostat
	Cylinder thermostat	N/A
	Boiler interlock	
	TRVs except in the room with a room thermostat	
	Automatic bypass valve	

Improving the fabric insulation may result in existing radiators being oversized for the new heating load. Thermostatic Radiator Valves (TRVs) will reduce the risk of overheating.

## 6.7 Controls

The central heating boiler (and pump) must turn off automatically when there is no demand for space or water heating (allowing for suitable pump over-run where required by some boilers). This is known as 'boiler interlock'.

Larger houses should be divided into zones with time and temperature controls for each. Generally the zones would be upstairs and downstairs, but in a building with significant solar gain they may be north and south facing areas.

Seven-day programmable thermostats are required in Scotland for regular and combi systems, and are recommended in Northern Ireland, England and Wales (except where user needs dictate otherwise). These allow different time and temperature settings for each day of the week. Some programmable thermostats incorporate hot water control but a separate hot water programmer is also acceptable.

Time and temperature controls that users find easy to understand and simple to adjust will be most effective.

## 6.8 High performance hot water cylinders

Rapid-recovery coils in hot water cylinders increase the rate of heat transfer into the water within the cylinder and reduce the recovery times. The principal advantages are:

- Reduced operating time for the boiler.
- Lower boiler return temperatures, improving boiler efficiency.
- A smaller hot water cylinder can be used, reducing standing losses.
- Additional insulation is standard, further reducing standing losses.

They are installed in the same way as conventional cylinders.

## 6.9 Pipework

All primary pipework must be insulated. In addition, any pipework outside the heated envelope of the dwelling must also be insulated to save heat loss and avoid freezing, and it is recommended that heating pipework in all floor voids is insulated.

The boiler should be positioned within the dwelling where possible and the length of the primary pipework runs to the hot water cylinder minimised. Likewise, the hot water cylinder should be positioned close to the kitchen and bathroom in order to minimise pipe runs.

## 6.10 Electric storage heating systems

The CO<sub>2</sub> emissions and running costs of conventional electric resistance heating systems will be higher than those for gas. They should therefore only be used in properties that have been insulated to a good standard.

The recommended electric heating packages include:

- Fan-assisted off-peak storage heaters with top-up on-peak convectors in living rooms.
- Storage heaters in large bedrooms and large kitchens.
- On-peak fixed convector heaters with time switches and thermostats in small bedrooms.
- On-peak downflow heaters in bathrooms and small kitchens.
- Automatic charge control and thermostatically controlled damper outlet on all storage heaters.
- Dual-immersion hot water cylinder with factory-applied insulation.
- Hot-water controller with one-hour on-peak boost facility.

Hot water cylinder capacities of between 110 litres (for small dwellings) and 245 litres (for large dwellings) are recommended.

Modern storage heaters with a fan are smaller and more responsive than older versions. A thermostat governs heat output/storage during off-peak and on-peak times which can be further controlled by a room thermostat. The on-peak convector control is wired to the thermostat and comes on only when the stored heat has been largely used up.

### 6.11 Communal systems

Group, district, community, or combined heat and power (CHP) heating systems can be installed in suitable developments. However, consideration needs to be given to metering, maintenance and management arrangements.

### 6.12 Alternative heating systems

#### Individual gas room heaters with instantaneous water heater

Given a good standard of insulation, two or three room heaters can often supply sufficient heat for a whole dwelling. Capital costs are low, but layout and design must ensure adequate distribution of heat.

#### Warm-air heating, stored hot water

In small, well-insulated dwellings, warm-air heating (comprising heat generator, ducts, and fans) is a simple option. Careful design is needed for good heat distribution and the unit must supply both space and water heating.

A variety of renewable and low-carbon heating systems are described on page 30.

#### Further Information

For more detailed guidance on space heating and hot water please see the following Energy Saving Trust literature:

- Central Heating System Specification (CHeSS) Year 2005 (CE51/GIL59).
- Domestic heating by oil: boiler systems (CE29).
- Domestic heating by gas: boiler systems (CE30).
- Domestic heating by solid fuel: boiler systems (CE47).
- Domestic heating by electricity (CE185).
- Community heating: a guide (CE55).

## 7 Energy Saving Trust technical recommendations – Lights and appliances

Electricity for lights and appliances (including cooking) can account for a significant proportion of total energy costs and CO<sub>2</sub> emissions. Landlords and developers can reduce these by:

- Specifying energy efficient lamps wherever appropriate and switches at all room exits.
- Encouraging gas cooking, if gas is available.
- Choosing low energy appliances.
- Providing occupants with information on the choice and use of low energy lights and appliances.
- Specifying onsite sustainable electricity sources such as photovoltaics (PV).

### 7.1 Lighting

Best practice: 75 per cent of all fixed luminaries should be dedicated, high-frequency, low-energy fittings.

Energy demand for lighting can be reduced by:

- Using energy efficient lamps and luminaries (light fittings).
- Directing light to where it is needed.
- Controlling lighting use.
- Making the most of daylight.

Immediate results can be made in the first three areas through basic home improvements.

The greatest savings will be achieved through periodic refurbishment work such as rewiring. Low energy lighting should be installed as part of the works.

Dedicated fittings will only accept particular types of lamp. A low energy lamp is one with a luminous efficacy greater than 40lm/W (lumens per Watt) – luminous efficacy is a measure of the energy efficiency. Compact and tubular fluorescent lamps both meet this requirement. Tungsten halogen lamps do not.

These low-energy lamps have a longer life than traditional tungsten lamps and use less energy. Many energy efficient lamps and dedicated fittings display the Energy Saving Recommended certification mark.

#### 7.2.1 Communal lighting

All communal lighting should be controlled; by time switches, photoelectric units, push-button controls, or Passive infra-red (PIR) presence detectors, as appropriate. Low-energy tubes or lamps should also be used, except where push-button time-delay switches or PIR are installed.

#### 7.2.2 External lighting

Exterior lighting on estates and in communal areas should use either:

- Incandescent lamps with photocells (daylight sensors) and PIR with a maximum lamp capacity of 150W OR
- Energy efficient lamps (efficacy of at least 40lm/W) and compatible photocell or timer.

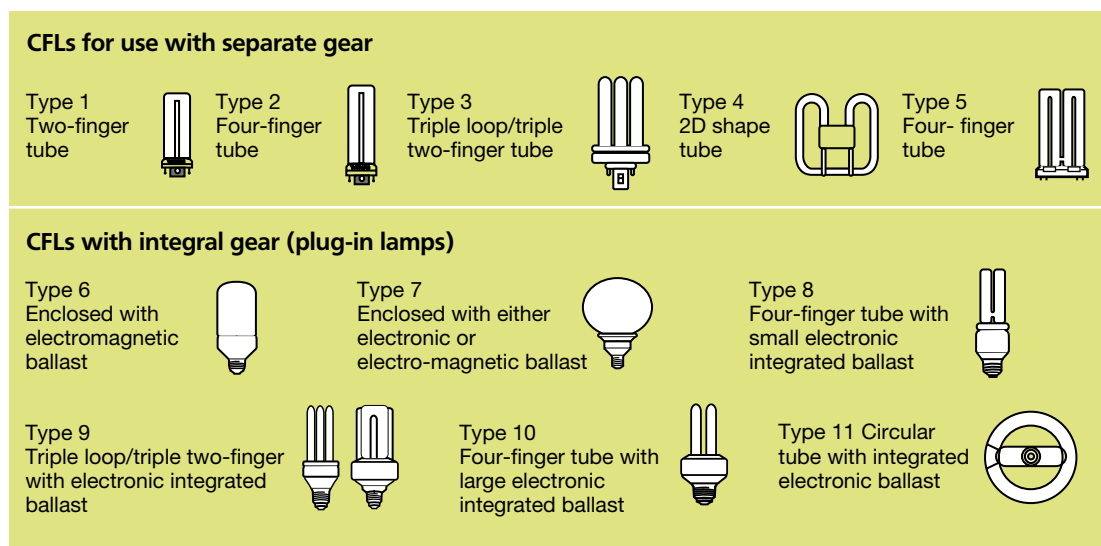

Figure 7.1 A range of CFL designs

### 7.2 Appliances

Best practice: specify Energy Saving Recommended appliances

Appliances account for a large proportion of total domestic energy use. As energy efficient appliances use less electricity, they are less expensive to run and are responsible for lower CO<sub>2</sub> emissions.

Appliances may be increasingly efficient, but our homes contain more and more of them. It is very important, therefore, to choose models that are energy efficient. There is often very little difference in capital cost but a great difference in running costs and CO<sub>2</sub> emissions. Energy labelling schemes make the selection of appliances simpler.

#### Further information

For more detailed guidance on lights and appliances please see the following Energy Saving Trust literature:

- Energy efficient lighting (CE61).
- Low energy domestic lighting (GIL20).
- Low energy domestic lighting: looking good for less (CE81/GPCS441).

### 7.3 Energy labels

In 1995 the European Union introduced a compulsory energy labelling scheme for household appliances, covering refrigerators, freezers and fridge-freezers. This scheme has since been extended to include washing machines, tumble dryers, washer-dryers, dishwashers, electric ovens and lamps. Energy labels are displayed on these products in shops and showrooms, in order to allow potential purchasers to compare their efficiencies.

The energy labels show estimated fuel consumption (based on standard test results) and an energy grading from A to G, where A is the most efficient (for cold appliances, A++ is the most efficient). An A-rated appliance will use approximately half as much electricity as a G-rated appliance.

However, the actual amount of electricity used will depend on how the appliance is used and where it is located. For example, a cold appliance (such as a fridge) that is placed next to a heater or oven will use more energy than one that is sited in a cooler place, so kitchen layout is important to energy efficiency.

Some labels now also provide information on other aspects of the performance of the appliance, e.g. washing performance, water usage per cycle, spin (for washing machines), etc.

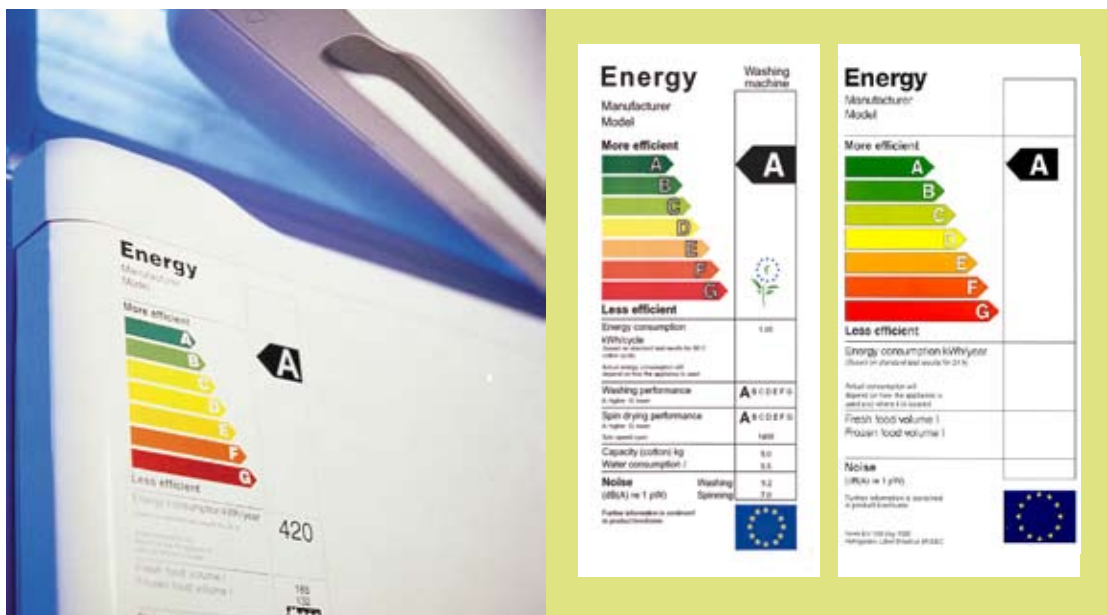

Figure 7.2 EU energy labels

**Table 7.1** Typical savings

A/A+ Rated Appliances	Typical Annual Saving (£/yr)*
Fridge Freezer (A+)	£37
Chest Freezer (A+)	£26
Upright Freezer (A+)	£26
Refrigerator (A+)	£16
Washing Machine (A)	£8
Dishwasher (A)	£16
*Based on an appliance purchased new in 1995 being replaced by an Energy Saving Recommended one.	

### 7.4 Energy saving recommended

The Energy Saving Trust manages a labelling scheme for products of proven energy efficiency. The scheme currently covers appliances (washing machines, fridges, freezers, dishwashers and tumble dryers), light bulbs and fittings, gas and oil boilers, heating controls, loft insulation, cavity wall insulation, external wall and dry-linings, high performance hot water cylinders and windows.

These products carry the 'Energy Saving Recommended' label. Currently endorsed products can be found at [www.energysavingtrust.org.uk/recommended](http://www.energysavingtrust.org.uk/recommended)

### 7.5 Providing information

Occupants should be given clear information on choosing low-energy appliances and energy efficient lighting. This should focus on the labelling schemes and is particularly important where appliances are not provided.

For further information on giving energy efficiency advice see the Energy Advice Handbook referenced in the Further information section of this guide.



Certification mark

## 8 Renewable and low-carbon technologies

Several types of renewable technologies can generate electricity for a dwelling or community, including photovoltaics (PV), wind and micro-CHP.

Other renewable, or low-carbon technologies can also provide heating and hot water, such as heat pumps, biomass and solar hot water. These can often be installed as part of a refurbishment project.

### 8.1 Photovoltaics (PV)

A PV panel will convert solar energy to electricity. Even in cloudy, northern latitudes, PV panels can generate power to meet some or all of a building's electricity demand. Installation can often be carried out with very little disruption to residents.

PV is a flexible and versatile technology. Panels can be used in roofs, curtain walls and decorative screens. PV can be used in glass roofs and in conservatories where it will also provide some solar shading. Here, these products serve the same structural and weather-protection purposes as traditional alternatives, as well as offering the benefit of power generation.

### 8.2 Wind power

There are many large estates where community wind turbines (CWT) might be appropriate. However, factors such as local wind regimes, planning permission, and noise levels have to be taken into account. Wind turbines work best on relatively open sites, but modern units on tall towers have opened up new possibilities.

### 8.3 Micro-CHP

Micro combined heat and power is an emerging technology, which is expected to play a significant role in future domestic energy provision. Micro-CHP units are about the same size as small domestic refrigerators or floor-mounted boilers, and are similar in appearance.

They are predominantly gas-powered, delivering between 1-3kW of electric power (1-3kWe), and 4-8kW of heat (4-8kWth). They can therefore provide space heating and hot water, as well as the additional benefit of electricity generation.

In currently available systems, heat is delivered to radiators by hot water, and domestic hot water is supplied by a conventional indirect storage cylinder. A micro-CHP unit can be connected into an existing wet heating system, often as a replacement for an existing boiler.

Dwellings are thus unlikely to require significant alteration and disruption to the occupants is minimised.

Micro-CHP systems with higher thermal outputs will help with hard-to-treat dwellings (those with solid walls, solid floors and no loft space) where there is a relatively large heat demand and energy efficiency measures are expensive. In this case, micro-CHP will produce fewer carbon emissions than a condensing boiler.

### 8.4 Biomass

If taken from a sustainable source, biomass fuels (including waste wood sources and farmed energy crops such as willow) are 'carbon neutral' apart from the small amount of CO<sub>2</sub> arising from the felling, processing and transportation.

Wood fuels come in three main forms:

- Logs.
- Chips.
- Pellets.

While biomass is well suited for use with 'wet' boiler-based heating systems, certain issues must be addressed if replacing a gas-fired boiler.

#### Monitoring and maintenance

Fuel consumption must be monitored to ensure adequate stocks. Automatic feed systems require maintenance and the residual ash has to be removed/disposed of.

#### Storage

Depending on the fuel and the regularity of deliveries, a large fuel storage facility may be required. Wood pellets are the most fuel dense and should be preferred where there is limited storage space.

#### Supply

There are currently only a few pellet suppliers, although the market is expanding. Up-to-date supplier information can be obtained from [www.logpile.co.uk](http://www.logpile.co.uk)

#### Quality

There is no UK standard for pellet quality. There is, however, a voluntary code of good practice and with the formation of the British Pellet Club there is progress towards standardisation.

### 8.5 Ground source heat pump (GSHP)

A GSHP transfers heat from the earth to the dwelling by means of an electric heat pump. A GSHP is a low-carbon technology, whilst it does consume electricity to power the heat pump unit a larger amount of useful heat is generated for every unit of electricity used.

The systems require collectors in the ground: these can be horizontal or vertical. Horizontal collectors are more economical but require sufficient available land near the dwelling.

The most obvious applications are for individual houses in rural areas away from gas mains and also low density urban housing with sufficient land. Groups of small blocks of flats may also be appropriate and GSHPs can be used to replace baseload boiler plant in communal heating systems.

Although the heat can be distributed through large radiators, underfloor heating is more efficient because it operates at lower temperatures, when heat pumps are more efficient.



**Figure 8.1** Evacuated tube collectors

### 8.6 Solar hot water (SHW)

SHW systems use the sun's energy to produce hot water. They are particularly appropriate where heating system improvements are already being undertaken and a solar collector can be fitted on the roof. The main types of system use either flat plate collectors or evacuated tube collectors. In both types, liquid in the solar collector is heated by the sun. This then passes through a coil in a hot water storage cylinder. The water in the cylinder can be used at this temperature, or raised to a higher temperature by a boiler or electric immersion heater.

These systems do not generally provide space heating and are described as 'solar thermal' systems. They are amongst the most cost-effective renewable energy systems for existing dwellings. During the summer months, a typical system can supply between 80 and 100 per cent of hot water demand, the percentage being much lower in winter, of course.

When using SHW heating in existing housing:

- Ensure an adequate area (typically 2-5m<sup>2</sup>) of south-oriented ( $\pm 45^\circ$ ) pitched roof is available (not shaded by chimneys, dormers, etc).
- Provide a larger hot water storage cylinder than would normally be needed for a gas-fired system.
- Check whether planning permission is needed for roof-mounted collectors, especially in conservation areas and other architecturally sensitive locations.

Even when it is decided not to include solar water heating, it is worth making properties 'solar ready', to allow systems to be added later with minimal disruption.

#### Further information

For more detailed guidance renewable and low-carbon technologies please see the following Energy Saving Trust literature:

- New and renewable energy technologies for existing housing (CE102).
- Renewable energy in existing homes – case studies (CE191).
- Renewable energy sources for homes in urban environments (CE69).
- Renewable energy sources for homes in rural environments (CE70).

## 9 Embodied energy

There is a growing urgency to reduce the environmental impacts of human activities. Energy efficiency initiatives over the last 40 years have reduced the energy consumption of buildings considerably, but action to minimize the impact from construction materials has been relatively slow.

There are two key elements to the energy use of a building. Energy used by occupants to run the building during its lifespan – known as operational energy; and energy used during the manufacture, maintenance and replacement of the components that constitute the building during its lifespan. This is known as embodied energy.

In older buildings operational energy has traditionally represented the major impact. As the energy efficiency standards of modern buildings have been raised the importance of embodied energy has increased.

Where the selection of products and materials directly affect the operational energy, the most efficient option should be selected. For those looking to maximise environmental benefit, or where products are very similar in terms of operational performance, then embodied energy aspects should also be taken into consideration.

# 10 Energy Saving Trust best practice guidance

The following publications can be obtained free of charge by telephoning the Energy Saving Trust on 0845 120 7799 or by visiting the website at [www.energysavingtrust.org.uk](http://www.energysavingtrust.org.uk)

## Whole house

- Domestic energy efficiency primer (CE101/GPG171)
- The effect of Building Regulations Part L1 (2006) on existing buildings (CE53)
- Refurbishing dwellings – a summary of best practice (CE189)
- Practical refurbishment of solid-wall houses (CE184/GPG294)
- Energy efficient historic homes – case studies (CE138)

## Home conversion and extensions

- Energy efficient loft conversion (CE120)
- Energy efficient garage conversions (CE121)
- Energy efficient domestic extensions (CE122)

## Insulation

- Effective use of insulation in dwellings (CE23)
- Insulation materials chart – thermal properties and environmental ratings (CE71)
- Cavity wall insulation in existing housing - A guide for specifiers and contractors (CE16)
- Internal wall insulation in existing housing (CE17/GPG138)
- External insulation systems for walls of dwellings (CE118/GPG293)
- Advanced insulation in housing refurbishment (CE97)

## Glazing

- Windows for new and existing housing (CE66)

## Ventilation

- Energy-efficient ventilation in housing (CE124/GPG268)
- Improving air tightness in dwellings (CE137/GPG224)

## Heating

- Central Heating System Specifications (CHeSS) – Year 2005 (CE51/GIL59)
- Domestic heating by gas: boiler systems (CE30)
- Domestic heating by oil: boiler systems (CE29)
- Domestic heating by solid fuel: boiler systems (CE47)
- Domestic heating by electricity (CE185)

## Lighting

- Energy efficient lighting (CE61)
- Low energy domestic lighting – looking good for less (CE81/GPCS441)
- Low energy domestic lighting (CE188/GIL20)

## Renewable energy

- New and renewable energy technologies for existing housing (CE102)
- Renewable energy in existing homes – case studies (CE191)
- Renewable energy sources for homes in urban environments (CE69)
- Renewable energy sources for homes in rural environments (CE70)

## Frequently asked questions

- Energy efficiency – frequently asked questions (CE126)

To obtain these publications or for more information, call 0845 120 7799  
email [bestpractice@energysavingtrust.org.uk](mailto:bestpractice@energysavingtrust.org.uk)  
or visit [www.energysavingtrust.org.uk/housing](http://www.energysavingtrust.org.uk/housing)

# 11 Further information

## Contacts

### Energy efficiency advice and grant information

The Energy Saving Trust manages a UK-wide network of Energy Efficiency Advice Centres (EEACs). Telephone 0800 512 012 to be automatically connected to the EEAC that covers your area, or visit [www.energysavingtrust.org.uk/myhome](http://www.energysavingtrust.org.uk/myhome)

### Insulation

Cavity Insulation Guarantee Agency (CIGA)  
Tel: 01525 853300  
[www.ciga.co.uk](http://www.ciga.co.uk)

National Insulation Association (NIA)  
Tel: 01525 383313  
[www.insulationassociation.org.uk](http://www.insulationassociation.org.uk)

British Polyurethane Foam Contractors Association (BUFCA)  
Tel: 01428 654011  
[www.bufca.co.uk](http://www.bufca.co.uk)

Insulated Render and Cladding Association (INCA)  
Tel: 01428 654 011  
[www.inca-ltd.org.uk](http://www.inca-ltd.org.uk)

### Glazing

Glass and Glazing Federation  
Tel: 0870 042 4255  
[www.ggf.org.uk](http://www.ggf.org.uk)

Fenestration Self-Assessment Scheme  
Tel: 0870 780 2028  
[www.fensa.co.uk](http://www.fensa.co.uk)

British Fenestration Rating Council (BFRC)  
[www.bfrc.org](http://www.bfrc.org)

### Draught-stripping

National Insulation Association (NIA)  
Tel: 01525 383313  
[www.insulationassociation.org.uk](http://www.insulationassociation.org.uk)

Draught Proofing Advisory Association Limited  
Tel: 01428 654011  
[www.dpaa-association.org.uk](http://www.dpaa-association.org.uk)

### Ventilation

Residential Ventilation Association  
[www.feta.co.uk/rva/](http://www.feta.co.uk/rva/)

The Electrical Heating and Ventilation Association  
Tel: 0207 793 3008  
[www.tehva.org.uk](http://www.tehva.org.uk)

### Heating and hot water

HHIC (Heating and Hot water Information Council)  
Tel: 0845 600 2200  
[www.centralheating.co.uk](http://www.centralheating.co.uk)

CORGI (Council of Registered Gas Installers)  
Tel: 0870 401 2200  
[www.corgi-gas-safety.com](http://www.corgi-gas-safety.com)

OFTEC (Oil-Firing Technical Association)  
Tel: 0845 6585080  
[www.oftec.org](http://www.oftec.org)

Heating Efficiency Testing and Advisory Service Ltd (HETAS Ltd)  
Tel: 01242 673257  
[www.hetas.co.uk](http://www.hetas.co.uk)

The Solid Fuel Association  
Tel: 0845 601 4406  
[www.solidfuel.co.uk](http://www.solidfuel.co.uk)

The British Electrotechnical and Allied Manufacturers' Association  
Tel: 020 7793 3000  
[www.beama.org.uk](http://www.beama.org.uk)

## 12 Publications

### **Building regulations and policy**

Energy White Paper: Our energy future – creating a low carbon economy, DTI, February 2003.

The Building Regulations 2000, Conservation of fuel and power, are detailed in Approved Document L1B – Work in existing dwellings (2006 Edition).

See [www.communities.gov.uk](http://www.communities.gov.uk)

Section 6: Energy, of the Domestic Technical Handbook outlines possible ways of complying with the Building (Scotland) Regulations 2007

See [www.sbsa.gov.uk](http://www.sbsa.gov.uk)

Building Regulations (Northern Ireland) 2000, are detailed in Technical booklet F1 2006, Conservation of fuel and power in dwellings.

See [www.dfpni.gov.uk](http://www.dfpni.gov.uk)

The Government's Standard Assessment Procedure for Energy Ratings of Dwellings. SAP 2005.

See [www.bre.co.uk/SAP2005/](http://www.bre.co.uk/SAP2005/)

### **Cavity wall insulation**

BS 5617:1985 'Specification for urea-formaldehyde (UF) foam systems suitable for thermal insulation of cavity walls with masonry or concrete inner and outer leaves'

[www.bsi-global.com](http://www.bsi-global.com)

BS 5618: 1985 'Code of practice for thermal insulation of cavity walls (with masonry or concrete inner and outer leaves) by filling with urea-formaldehyde (UF) foam systems'

[www.bsi-global.com](http://www.bsi-global.com)

### **Ventilation**

Background ventilators for dwellings  
IP2/2003, BRE, 2003.

### **Embodied energy**

BR390 The Green Guide to Housing Specification, Anderson and Howard, BRE, 2000

Life Cycle Assessment of PVC and of principal competing materials. Commissioned by the European Commission, April 2004.

### **EcoHomes XB**

The environmental rating for existing dwellings.

[www.breeam.org](http://www.breeam.org)

### **Energy Advice Handbook**

The energy advice handbook is an essential reference book for energy advisors and those interested in domestic energy issues.

Tel: 01457 873610

[www.energyinform.co.uk](http://www.energyinform.co.uk)



energy saving trust™

**Energy Saving Trust**, 21 Dartmouth Street, London SW1H 9BP Tel 0845 120 7799 Fax 0845 120 7789  
bestpractice@est.org.uk www.est.org.uk/housingbuildings

CE83 © Energy Saving Trust December 2003. Revised September 2006. E&OE

This publication (including any drawings forming part of it) is intended for general guidance only and not as a substitute for the application of professional expertise. Anyone using this publication (including any drawings forming part of it) must make their own assessment of the suitability of its content (whether for their own purposes or those of any client or customer), and the Energy Saving Trust cannot accept responsibility for any loss, damage or other liability resulting from such use. So far as the Energy Saving Trust is aware, the information presented in this publication was correct and current at time of last revision. To ensure you have the most up-to-date version, please visit our website: [www.est.org.uk/housingbuildings/publications](http://www.est.org.uk/housingbuildings/publications). The contents of this publication may be superseded by statutory requirements or technical advances which arise after the date of publication. It is your responsibility to check latest developments.

All technical information was produced by BRE on behalf of the Energy Saving Trust.

Printed on Revive Silk which contains 75% de-inked post consumer waste and a maximum of 25% mill broke.

