

Entrance hall and reception area

- The reception point should be easily identifiable from the entrance doors or lobby.
- A lower part of any reception desk should be included for use by wheelchair users, at least 1500mm wide, with its surface no higher than 760mm and a knee recess 700mm high, 500mm deep and 900mm wide provided underneath.
- There should be a clear space at least 1200mm deep and 1800mm wide in front of the reception desk (1400mm deep and 2200mm wide if there is no knee recess).
- The reception desk should be fitted with an induction loop or other hearing enhancement system, and its presence indicated by the standard pictographic sign.
- any screen in front of the reception desk should be glazed in non-reflective material so that someone who lipreads has a good view of the speaker.
- Good information and directional signage should be provided in reception areas.

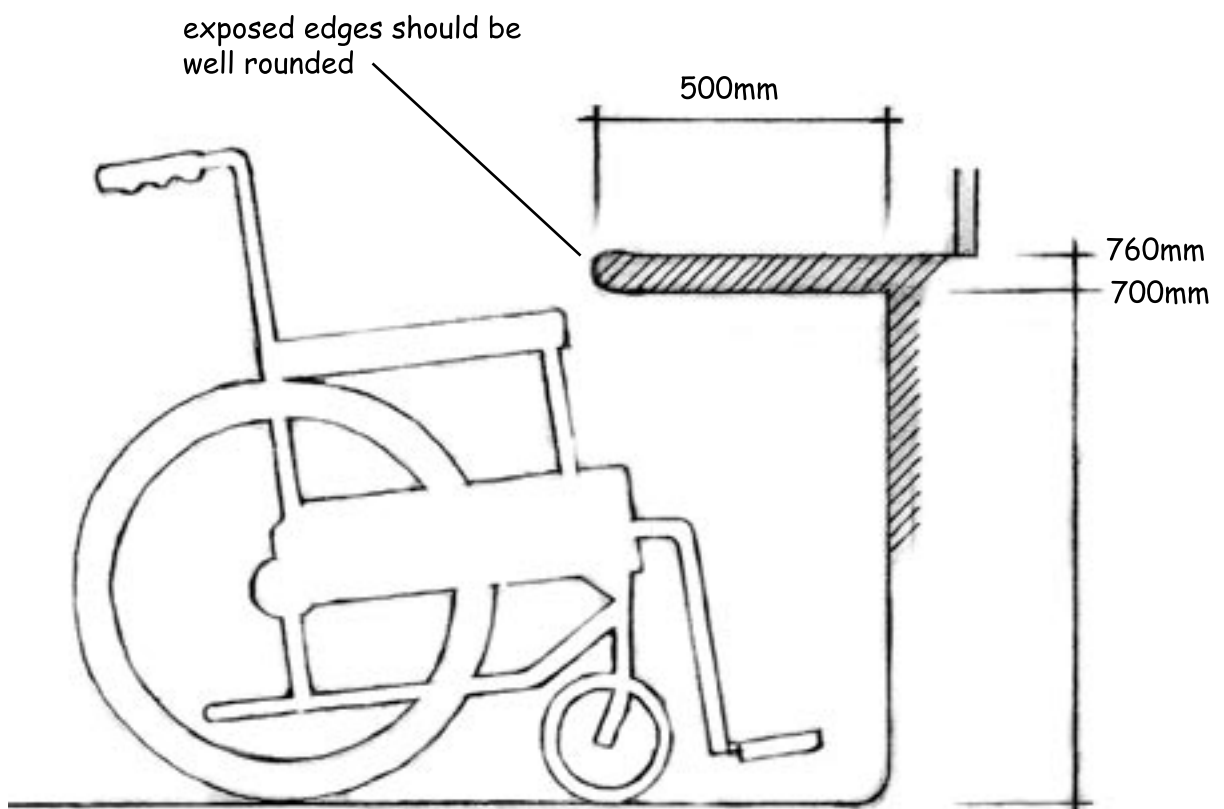

8. ENTRANCE HALLS AND RECEPTION AREAS
